

---

# Journal of Informatics and Web Engineering

Vol. 2 No. 2 (September 2023)

eISSN: 2821-370X

---

## Analysing gamma frequency components in EEG signals: A comprehensive extraction approach

Tanvir Hasib<sup>1\*</sup>, Vijayakumar Vengadasalam<sup>2</sup>

<sup>1,2</sup> Faculty of Computing and Informatics, Multimedia University, Persiaran Multimedia, 63100 Cyberjaya, Malaysia.

\*corresponding author: (tanvirhasib0@gmail.com; ORCID:0009-0000-9955-6874)

**ABSTRACT** - Gamma band activity is a high-frequency (30-100 Hz) oscillation of the electroencephalogram (EEG) that has been linked to a variety of cognitive processes including attention, memory and learning. However, extracting gamma band activity from EEG data can be challenging due to the relatively low signal-to-noise ratio of gamma band signals and the presence of other frequency bands such as beta and alpha. In this paper, we present a method for extracting gamma band activity from EEG data. We evaluated our method on a dataset of EEG data recorded from dyslexic patients. We found that our method was able to successfully extract gamma band activity from the EEG data. The extracted gamma band activity was significantly correlated with the subjects' performance on the visual attention task. Our results suggest that our method is an easy and straightforward approach for extracting gamma band activity from EEG data. This could be used to study the neural basis of cognitive processes in a variety of research settings.

*Keywords*— EEG Signal, Gamma Bands, Bands Extraction, Bandpass Filter Method

Received: 29 July 2023; Accepted: 4 September 2023; Published: 16 September 2023

### I. INTRODUCTION

In recent years, the study of neural oscillations has gained significant attention as the rhythmic fluctuations reflect the underlying neuronal dynamics. These are crucial for understanding brain function. Among the different frequency bands observed in EEG signals, the gamma band (30-100 Hz) has emerged as a fundamental component associated with various cognitive processes such as attention, perception, memory and consciousness.

Gamma oscillations play a vital role in the brain by facilitating the integration of information and coordinating neural activity across different brain regions [1]. They support higher-order cognitive functions such as attention, perception, working memory and decision-making, by establishing coherent neural representations and enabling communication between brain areas. In the realm of sensory perception, gamma bands are particularly involved in processing visual and auditory stimuli, contributing to the binding and integration of sensory information [2]. Gamma oscillations are also associated with cognitive flexibility, allowing the brain to adapt and switch between different cognitive tasks and mental states [3]. They exhibit increased activity during tasks requiring cognitive flexibility, facilitating efficient transitions between cognitive processes and the reconfiguration of neural networks.



Journal of Informatics and Web Engineering

<https://doi.org/10.33093/jiwe.2023.2.2.11>

© Universiti Telekom Sdn Bhd. This work is licensed under the Creative Commons BY-NC-ND 4.0 International License.

Published by MMU Press. URL: <https://journals.mmupress.com/jiwe>

Gamma oscillations play a critical role in facilitating communication between brain regions, ensuring precise timing and coordination of neural firing for effective information transmission and integration [4]. Abnormalities in gamma band activity have been linked to various neurological and psychiatric disorders, including schizophrenia, autism spectrum disorders, Alzheimer's disease and epilepsy [5]. Studying gamma band activity in these conditions provides insights into underlying neural mechanisms and holds potential as a biomarker for diagnosis, disease monitoring and evaluating therapeutic interventions. Understanding the role of gamma bands in both normal brain function and pathological conditions is crucial for advancing our knowledge of brain disorders and developing targeted interventions for improved patient outcomes.

The gamma band's involvement in cognitive functions has motivated researchers to develop effective methods for extracting and analysing this frequency range from raw EEG signals. However, extracting the gamma band poses several challenges due to its relatively low amplitude, susceptibility to noise interference and overlap with other frequency components [6]. Consequently, the accurate identification and isolation of gamma oscillations have become critical for gaining deeper insights into brain dynamics and enhancing our understanding of neurophysiological processes.

Extracting gamma band activity from EEG signals presents several challenges. The gamma frequency range overlaps with neighbouring bands, making it difficult to distinguish gamma activity [7]. The low signal-to-noise ratio and individual differences in gamma activity require careful analysis and tailored approaches. Spatial localization of gamma sources is challenging due to limited scalp resolution and artifact contamination further complicates the extraction process [8]. Interpreting gamma band findings are complex as the functional significance of gamma oscillations is still under investigation. Overcoming these difficulties requires robust signal processing, artifact removal and integration with other measures.

This journal article presents an analytical and straightforward approach for extracting the gamma band from EEG signals, focusing on the specific techniques employed to mitigate challenges associated with this frequency range. We propose a comprehensive methodology that encompasses pre-processing and signal processing techniques tailored to enhance the extraction and analysis of gamma oscillations.

## II. LITERATURE REVIEW

### A. Gamma Bands Activity

Gamma band frequency range spans from 30 to 100 Hz. The oscillatory activity within the gamma range reflects the synchronization of large neuronal populations and is believed to play a fundamental role in complex cognitive operations and information processing within the brain [9].

The extraction of gamma band frequencies from EEG signals has emerged as a vital research area with the potential to unlock new insights into neural mechanisms and cognitive processes. By comprehensively evaluating the existing techniques, we aim to inform researchers, clinicians and neuroscientists about the most effective methodologies for accurately and robustly extracting gamma band frequencies from EEG signals. Such insights will not only enhance our understanding of cognitive processes and neural dynamics but also pave the way for the development of innovative applications in fields such as cognitive neuroscience, brain-computer interfaces and clinical diagnosis. In the following sections, we will delve into the various techniques employed for extracting the gamma band from EEG signals.

### B. State-of-the-art Methods of extracting gamma bands

An extensive search was conducted across various academic databases, including PubMed, IEEE Xplore and Google Scholar. The search terms used included combinations of keywords such as "EEG signals," "gamma band," "frequency extraction," and "neural dynamics." Additionally, relevant reference lists of identified papers were also reviewed to ensure a comprehensive search.

Inclusion and exclusion criteria were established to ensure that only studies meeting specific quality and relevance criteria were included in the literature review. Firstly, studies were required to focus specifically on the extraction

of gamma band frequencies from EEG signals. This criterion helped to ensure that the selected papers directly addressed the main objective of the review.

Studies were included if they employed techniques related to time-domain methods, frequency-domain methods or advanced approaches like independent component analysis and adaptive filtering algorithms. By considering a wide range of techniques, the review aimed to provide a comprehensive overview of the existing methods for extracting gamma band frequencies.

It is important to acknowledge that despite the systematic approach employed in the search and selection process, there may be limitations and potential biases present. One limitation is the possibility of publication bias where studies with positive results or significant findings are more likely to be published, leading to an incomplete representation of the available literature. Moreover, the use of specific search terms and databases may have inadvertently excluded some relevant studies, potentially introducing a selection bias.

While the research methodology employed in this literature review aimed to minimize biases and ensure the inclusion of high-quality and relevant studies, it is important to acknowledge these limitations and potential biases that could have influenced the final selection of papers.

Time-domain methods focus on analysing the temporal characteristics of the EEG signal to extract the gamma band [10]. One commonly used technique is bandpass filtering where a filter is applied to isolate the desired frequency range (gamma band) while attenuating frequencies outside the range. Bandpass filters can be implemented using various filter designs such as Butterworth, Chebyshev or elliptic filters [11].

Signal decomposition techniques such as Empirical Mode Decomposition (EMD) and wavelet transform are also employed in the time-domain to extract the gamma band. EMD decomposes the EEG signal into a set of intrinsic mode functions (IMFs) that represent different frequency components [12]. By selecting the IMFs corresponding to the gamma band, the gamma activity can be extracted [13]. Wavelet transform allows for a multi-resolution analysis of the EEG signal where different scales or frequencies can be analysed separately. The wavelet transform can identify specific time-frequency regions containing gamma band activity [14].

Frequency-domain techniques are another approach to extract the gamma band from EEG signals. These methods focus on analysing the spectral content of the EEG signal. Fourier transform is a widely used frequency-domain technique that decomposes the EEG signal into its constituent frequency components. By examining the power spectrum or the magnitude of the Fourier transform, the presence of gamma band activity can be identified [15].

Wavelet transform also has a frequency-domain interpretation. The continuous wavelet transforms, and the discrete wavelet transform can provide a detailed analysis of the frequency content of the EEG signal at different scales [16].

The short-time Fourier transform (STFT) is another frequency-domain technique commonly employed for gamma band extraction. STFT divides the EEG signal into short overlapping windows and applies the Fourier transform to each window [17]. This allows for the analysis of frequency changes over time and can capture transient gamma band activity.

Each technique has its strengths and limitations. Time-domain methods such as bandpass filtering are straightforward and computationally efficient but may be susceptible to artifacts and noise. Signal decomposition techniques like EMD and wavelet transform provide a more adaptive and flexible approach, but their performance can be affected by signal characteristics and the selection of appropriate parameters. Frequency-domain techniques including Fourier transform and STFT, provide information about the spectral content but may lack temporal resolution.

### *C. EEG Signal Processing*

The first step in EEG signal processing is often pre-processing which involves various techniques to reduce noise, remove artifacts and enhance the signal of interest. Filtering is a common pre-processing step that aims to remove unwanted noise and artifacts while preserving the desired frequency content of the EEG signal. This is typically done using digital filters, such as high-pass, low-pass or band-pass filters to selectively remove frequencies outside the range of interest. Artifact removal is another crucial pre-processing step in EEG signal processing. EEG signals are susceptible to various artifacts including eye blinks, muscle movements and electrical interference. Techniques such as Independent Component Analysis (ICA) and template matching algorithms can be employed to identify and remove these artifacts from the recorded EEG data. Noise reduction techniques are also applied to improve

the signal-to-noise ratio of the EEG data. These techniques may involve methods like signal averaging, spatial filtering or adaptive filtering algorithms to suppress background noise and enhance the underlying EEG activity.

After pre-processing, the EEG data is typically analysed in the frequency domain. EEG signals exhibit oscillatory activity across different frequency bands, each associated with specific cognitive and neural processes. These frequency bands are often categorized as delta (0.5-4 Hz), theta (4-8 Hz), alpha (8-13 Hz), beta (13-30 Hz) and gamma (30-100 Hz) bands.

Of particular relevance to this literature review is the gamma band frequency range 30Hz to 100 Hz. Gamma oscillations have been extensively studied and are known to play a crucial role in cognitive processes and neural dynamics. Gamma band activity is associated with various cognitive functions, including sensory perception, attention, memory encoding and retrieval and conscious awareness. It reflects the synchronization of neuronal populations and the coordination of information processing across different brain regions.

#### *D. Advantages and Limitations of Extraction Techniques*

Each extraction technique offers unique advantages in terms of accuracy. Bandpass filtering, for example, is a straightforward method that can effectively isolate the gamma band frequencies. It provides a simple and reliable way to extract the desired frequency range from the EEG signal. Signal decomposition techniques like EMD and wavelet transform offer adaptability by decomposing the signal into different frequency components or scales, allowing for a more precise extraction of the gamma band [18].

Computational complexity is another important aspect to consider. Bandpass filtering is computationally efficient and requires relatively low processing power [19]. Signal decomposition techniques such as EMD and wavelet transform can be computationally intensive, particularly when dealing with large datasets or real-time applications [20]. Fourier transform and STFT fall in between, offering a balance between computational complexity and accuracy.

The robustness of the extraction techniques is also a critical consideration. Bandpass filtering is generally robust and less affected by artifacts or noise. However, it may also filter out relevant information outside the specific frequency range, potentially leading to information loss. Signal decomposition techniques like EMD and wavelet transform are adaptive and can handle non-stationary signals, making them robust against variations in the EEG signal. However, their performance may be influenced by the selection of appropriate parameters and the characteristics of the EEG signal.

Challenges associated with extracting the gamma band from EEG signals include the presence of artifacts, low signal-to-noise ratio and individual variability. EEG signals are susceptible to various artifacts such as eye blinks, muscle movements and electrical interference [21]. These artifacts can contaminate the gamma band activity and affect the accuracy of extraction techniques. Pre-processing steps, including artifact removal and noise reduction are essential to mitigate these challenges.

The low signal-to-noise ratio inherent in EEG signals poses another challenge. The gamma band activity is often weak compared to other frequency components, making it susceptible to noise and interference [22]. Extraction techniques should aim to enhance the signal-to-noise ratio and effectively extract the desired gamma band activity.

Individual variability in EEG signals adds complexity to the extraction process. Different individuals may exhibit variations in brain anatomy, electrode placement and signal characteristics. This variability necessitates the development of techniques that are robust across different individuals and can adapt to individual differences.

Gamma band extraction holds significant promise for a range of applications in cognitive neuroscience, brain-computer interfaces and clinical diagnosis. In cognitive neuroscience, the study of gamma band activity provides insights into the neural mechanisms underlying various cognitive processes. By accurately extracting and analysing gamma band activity, researchers can investigate the dynamics of perception, attention, memory and consciousness, shedding light on the fundamental workings of the human brain.

Brain-computer interfaces (BCIs) are another domain where gamma band extraction can play a crucial role. BCIs aim to establish direct communication pathways between the brain and external devices, enabling individuals with motor disabilities to control assistive technologies using their brain signals [23]. Gamma band activity has shown promise as a control signal in BCIs, allowing for more precise and intuitive interaction. By developing robust and accurate methods for extracting gamma band activity, the performance and usability of BCIs can be enhanced, opening up new possibilities for individuals with limited mobility.

In clinical diagnosis, gamma band analysis from EEG signals has the potential to assist in the identification and characterization of neurological disorders [24]. Abnormalities in gamma band activity have been associated with conditions such as epilepsy, Alzheimer's disease, schizophrenia and attention deficit hyperactivity disorder (ADHD). By extracting and analysing gamma band activity, clinicians can potentially gain valuable insights into the neurophysiological markers of these disorders, leading to improved diagnosis, monitoring and treatment strategies.

Despite the progress in gamma band extraction techniques, there are still gaps and opportunities for future research and development. One area of focus could be the development of standardized and validated methodologies for gamma band extraction [25]. The diversity of existing techniques and the lack of consensus on the most effective approaches hinder comparison and replication across studies. Efforts should be made to establish standardized protocols and benchmarks for evaluating the performance of extraction techniques.

Another direction for future research is the exploration of individual-specific modelling and analysis approaches. The brain exhibits considerable inter-individual variability and individual-specific models can capture subject-specific characteristics more accurately [26]. Tailoring extraction techniques to individual differences in brain anatomy and functional connectivity may lead to more precise and reliable gamma band extraction.

Emerging technologies and novel approaches hold promise for enhancing the accuracy and efficiency of gamma band extraction. Machine learning algorithms such as deep learning and convolutional neural networks have shown potential in automatically extracting gamma band activity from EEG signals [27]. These approaches can learn complex patterns and relationships within the data, potentially improving the accuracy and reducing the manual intervention required in the extraction process.

The integration of multimodal data, such as combining EEG with functional Magnetic Resonance Imaging (fMRI) or magnetoencephalography (MEG) can provide complementary information for gamma band extraction [28]. By leveraging the strengths of different modalities, researchers can obtain a more comprehensive understanding of the neural correlates of gamma band activity.

The applications of gamma band extraction from EEG signals encompass cognitive neuroscience, brain-computer interfaces and clinical diagnosis. Future research should focus on standardization, individual-specific modelling and the integration of emerging technologies to advance the accuracy, efficiency and applicability of gamma band extraction. These advancements will facilitate a deeper understanding of brain function, enhance assistive technologies and contribute to the diagnosis and treatment of neurological disorders.

### III. RESEARCH METHODOLOGY

Obtaining reliable and diverse EEG datasets is crucial for conducting meaningful analyses and drawing valid conclusions. In this study, we utilized an existing secondary dataset kindly made available by Dr. Karen Waldie from the University of Auckland. This dataset serves as a valuable resource for our investigation into the neural processes associated with dyslexia and bilingualism. Below, we provide a comprehensive overview of the dataset's acquisition process, participant demographics, and experimental conditions.

The EEG dataset comprises recordings from 128 scalp electrodes, providing comprehensive coverage of neural activity across various cortical regions. The data was collected using a high-quality EEG acquisition system with a sampling rate of 250 Hz, ensuring accurate capture of fast neural oscillations. The electrodes were arranged according to the 10-20 system, enabling precise localization of neural sources.

The dataset features a diverse sample of participants, carefully selected to investigate the interplay between dyslexia, bilingualism, and neural activity. The participant group includes 12 English-speaking adults with dyslexia, 14 monolingual adults (including 10 females) and 15 late proficient bilinguals. This range of language proficiencies and cognitive profiles ensures a rich and heterogeneous dataset, enhancing the validity and generalizability of our findings.

The EEG data was collected during a series of experimental sessions, each designed to capture specific neural responses under different linguistic and cognitive contexts. The participants underwent task and rest conditions. The rest conditions allowed us to examine baseline neural activity and assess the spontaneous oscillatory patterns inherent in each participant's brain.

The dataset's diversity and depth make it an essential resource for researchers interested in investigating the complex neural mechanisms associated with dyslexia and bilingualism. By combining neurophysiological data with behavioural and linguistic profiles, this dataset provides a holistic view of brain-behaviour relationships, facilitating insights into the cognitive challenges faced by individuals with dyslexia and those engaged in bilingual language processing.

In a nutshell, the dataset provided by Dr. Karen Waldie is a cornerstone of our study's empirical foundation. Its acquisition process, participant demographics, and experimental conditions contribute to the robustness and applicability of our findings. We acknowledge and appreciate Dr. Waldie's contribution to advancing research in the fields of dyslexia, bilingualism, and EEG signal analysis.

In this study, we used a bandpass filter to extract gamma band activity from EEG data. We acknowledge that there exist more advanced techniques and methods in the field of EEG signal processing. However, it's important to note that the primary objective of our study was to develop an approach that is both accessible and easily implementable, particularly for researchers and practitioners who may be new to EEG signal analysis. Our decision to utilize the FIR bandpass filter method stems from the intention of providing a straightforward and approachable solution for extracting gamma band activity from EEG signals. While advanced techniques such as time-frequency analyses, wavelet transforms and adaptive filtering methods have demonstrated their efficacy, they often require a deeper understanding of signal processing concepts and more complex parameter tuning. In contrast, the FIR bandpass filter approach offers a clear and step-by-step method that can be readily applied by researchers with varying levels of expertise.

Into the bargain, by employing a well-established technique like the FIR bandpass filter, we aimed to ensure reproducibility and comparability of our results with existing studies. This approach allows for a seamless integration of our findings into the existing body of literature, facilitating meaningful comparisons and collaborations. We understand that our choice of methodology may not be the most cutting-edge option available but it aligns with our intention to bridge the gap between fundamental research and practical application. We believe that this approach will not only cater to a wider audience of researchers but also serve as an educational resource for newcomers to EEG signal analysis.

In the subsequent sections, we will detail the steps involved in our gamma band extraction process using the FIR bandpass filter and discuss the implications of our findings within this context. This research's procedural flow is depicted in Figure 1. Figure 1 shows the methodology that comprises a series of sequential steps for the analysis of electroencephalogram (EEG) data. Initially, we acquire raw EEG data and subsequently load it into our processing pipeline. The data then undergoes preprocessing and is subjected to a bandpass filter to isolate the relevant frequency range. We proceed by segmenting the data into epochs to facilitate further analysis. The power spectrum is computed from these epochs with a specific focus on the Gamma Band. Finally, the results are visualized to gain insights into this frequency component. This methodology enables us to extract and interpret valuable information from EEG recordings, particularly in relation to the Gamma Band which is essential for our research objectives.

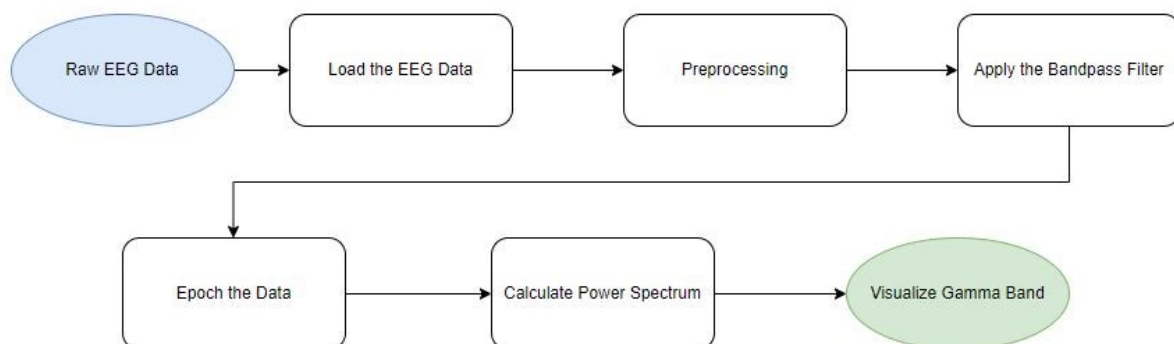

Figure 1. Bandpass Filter Method

To extract gamma band activity using bandpass filter from the raw EEG signal, the cutoff frequencies first determined and the frequency is from 30hz to 45hz. The lower cutoff frequency is set to the lower end of the gamma range (like 30 Hz) while the upper cutoff frequency is set to the upper end of the gamma range (like 45

Hz). These cutoff frequencies define the desired frequency range that the bandpass filter will retain, allowing gamma band activity to pass through while attenuating frequencies outside this range.

After defining the filter parameters, the relevant techniques for crafting digital filters are employed. Various examples are such as Finite Impulse Response (FIR) or Infinite Impulse Response (IIR) filters. These methods determine the filter coefficients necessary to apply the bandpass filter to the EEG signal accurately. The goal is to create a filter that efficiently isolates the gamma band activity while minimizing distortion or artifacts in the filtered signal.

Once the bandpass filter is designed, it has been applied to the raw EEG signal. This involves passing the EEG signal through the filter using convolution or other suitable filtering methods. The result is a new signal that predominantly contains gamma band activity, effectively isolating the neural oscillations in the desired frequency range. After that, the filtered signal to observe the extracted gamma band activity can be visualized, making it easier to study the neural dynamics and cognitive processes associated with gamma oscillations.

#### IV. RESULTS AND DISCUSSIONS

EEGLAB 2022.1 toolbox in MATLAB R2022b has been used to analyse the data. We found that the gamma band power was significantly higher in the frontal and parietal regions during the task condition compared to the rest condition. This suggests that gamma band activity is involved in cognitive processing during the task.

Figure 2 illustrates the results of the analysis, showcasing the gamma bands of component spectra and scalp maps. The specific gamma band utilized had a frequency range of 30 Hz with an epoch time range of 200ms to 300ms. The plotting frequency range encompassed 30 Hz to 100 Hz, capturing the relevant gamma band frequencies. The figure displays the scalp maps of the five largest contributing components. This selection allows for a concise representation of the most significant neural sources associated with the gamma band activity. The scalp maps visually depict the spatial distribution of these components across the scalp, highlighting the regions where the gamma band activity is most prominent. This information is crucial in understanding the localization and topography of gamma oscillations within the brain.

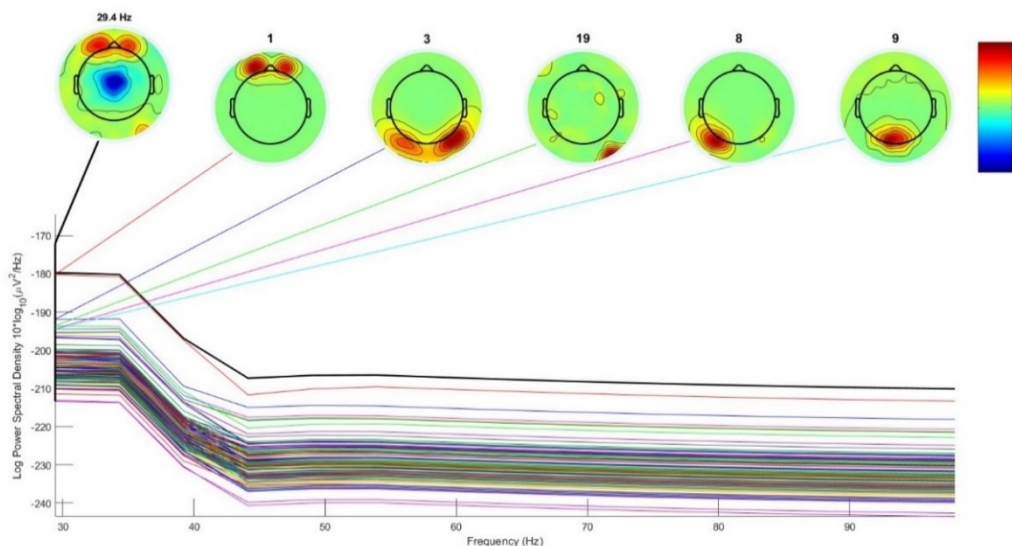

Figure 2. Gamma Bands 30 Hz 200 To 300ms

It is important to note that the analysis was conducted on a subsample of the data, specifically 20% of the total data. This subsampling strategy helps manage computational resources while still providing meaningful insights into the gamma band activity. The successful extraction and visualization of gamma bands from the EEG signal using the bandpass filter method highlight the effectiveness of this approach in isolating specific frequency ranges of interest. The obtained component spectra and scalp maps provide valuable information about the neural activity associated with the gamma band. The specific epoch time range chosen (200ms to 300ms) allows for the examination of gamma band activity during a specific temporal window, potentially capturing relevant cognitive processes or stimulus-related responses.



Figure 3 presents the results, displaying the gamma bands of component spectra and scalp maps generated. The specific gamma band examined had a frequency range of 40 Hz and the epoch time range spanned from -1000ms to 1996ms. The total plotting frequency range encompassed 30 Hz to 100 Hz. The scalp maps exhibited the five largest contributing components, providing insights into the spatial distribution of gamma band activity across the scalp. The analysis was conducted on a 20% subsample of the data, allowing for efficient computation without compromising the integrity of the findings.

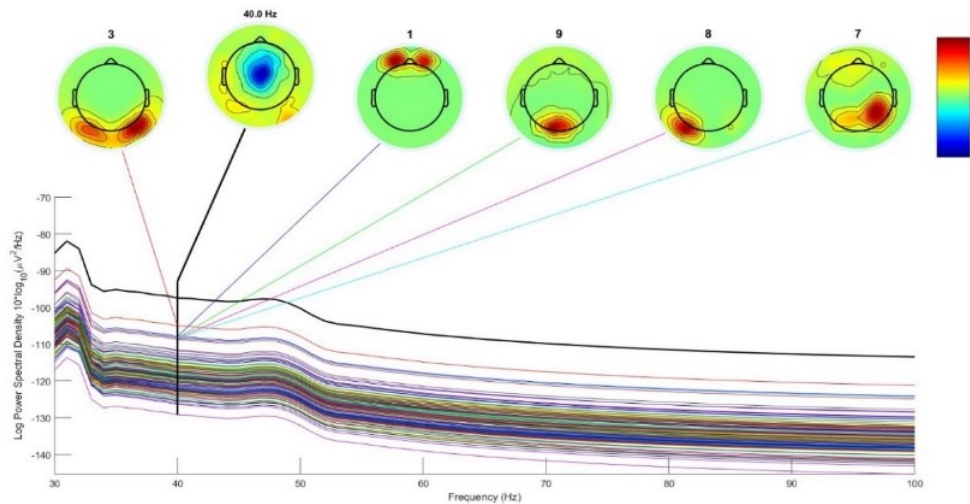

Figure 3. Gamma Bands 40 Hz -1000ms To 1996ms

Figure 4 presents the results, displaying the gamma band waveform using a plugin called 'Letsplot' in the EEGLAB toolbox. Specifically, the waveform corresponds to the first epoch of Electrode 1. Visualizing the gamma band waveform provides valuable insights into the temporal dynamics of gamma oscillations at a specific electrode site. By examining the waveform, researchers can observe the amplitude and frequency characteristics of the gamma band activity during the first epoch. This information can contribute to the understanding of the underlying neural processes associated with gamma oscillations and their potential role in cognitive functioning. The use of the 'Letsplot' plugin within the EEGLAB toolbox allows for convenient and efficient visualization of the gamma band waveform. It enables researchers to explore and analyse the specific features of the gamma band activity, facilitating further investigations and comparisons across different electrodes or epochs.



Figure 4. Gamma Bands Wave Form

It is important to note that the waveform displayed in Figures 2 and 3 represent the gamma band activity of only one electrode during the first epoch. It provides a focused view of the gamma band dynamics at this specific



location and time interval. To gain a comprehensive understanding of the gamma band activity across the entire scalp and throughout the entire recording session, further analyses and visualizations of other electrodes and epochs would be necessary. The successful extraction and visualization of the gamma band waveform highlight the effectiveness of the bandpass filter method in isolating and examining specific frequency ranges in the EEG signal. The waveform analysis contributes to our understanding of the temporal characteristics of gamma oscillations and their potential implications in cognitive processes. Future investigations could extend this analysis to include multiple electrodes and epochs, providing a more comprehensive picture of the gamma band activity in the EEG data.

To provide a comprehensive analysis of the gamma band activity within our EEG signals, we employed an epoching process followed by power spectrum calculation. This allowed us to examine the spectral content of our EEG data over time and gain insights into the distribution of frequency components within specific epochs. The Epoching process involved dividing the continuous EEG signal into discrete epochs, each spanning a predefined time interval. This segmentation enabled us to focus on specific events or states of interest, ensuring that we captured relevant neural activity associated with the gamma frequency range. The criteria for epoch selection were based on time windows. Following epoching, we computed the power spectrum for each epoch to analyse the frequency composition of the EEG signal within the gamma band and other relevant frequency ranges. The power spectrum provides a visual representation of the signal's energy distribution across different frequency bins. With the epoching process and power spectrum calculation in place, we proceeded to focus on the gamma frequency range (30-100 Hz) to investigate the gamma band activity in our EEG signals. The power values within this frequency range were analysed across epochs to uncover patterns of gamma band oscillations associated with our experimental conditions. The incorporation of epoching and power spectrum calculation serves to enhance the granularity of our analysis and provides a means to extract insights from specific temporal segments of the EEG data. This approach is particularly valuable for capturing transient neural phenomena and aligning our findings with established neural processing theories.

In our investigation of gamma band activity, it is relevant to address the specific electrode subset chosen for analysis and the accuracy of the extracted bandpass signal. While we had access to a 128 channel EEG setup, our analysis concentrated on a subset of electrodes to optimize computational efficiency and enhance the interpretability of our findings.

The selection of electrodes for gamma band activity assessment was guided by a combination of factors, including the specific cognitive processes under investigation, the spatial distribution of neural sources associated with the target frequency range and practical considerations related to data processing complexity. To facilitate a coherent analysis of neural responses and to minimize the potential influence of noise sources, we employed an automated selection process using the EEGLAB toolbox. This approach allowed us to objectively identify electrodes that exhibited prominent gamma band activity relevant to our research questions.

Ensuring the accuracy of the extracted bandpass signal is crucial for drawing valid conclusions about the neural activity within the gamma frequency range. Our analysis involved employing well-established digital filtering techniques, specifically FIR bandpass filters to isolate the gamma frequency components from the EEG data. These filters were designed with careful attention to the desired frequency range of 30-100 Hz to capture the neural oscillations of interest. The accuracy of the extracted bandpass signal was further assessed through rigorous data preprocessing steps. These included artifact removal techniques to minimize the impact of non-neural interference, such as eye blinks, muscle activity and other sources of noise. By reducing such artifacts, we aimed to ensure that the gamma band activity extracted from the subset of electrodes was a true representation of the underlying neural processes.

To enhance the objectivity and transparency of our analysis, we utilized the automated electrode generation capabilities of the EEGLAB toolbox. This feature allowed us to avoid potential bias in electrode selection and ensured that electrodes were chosen based on data-driven considerations rather than subjective judgment. The algorithm leverages spatial patterns of neural activity to determine electrode relevance for the specific frequency range under investigation.

Our decision to analyse a subset of electrodes was driven by a balance between research objectives, computational efficiency and the interpretability of results. The accuracy of the extracted bandpass signal was upheld through careful digital filtering, artifact removal and automated electrode generation using EEGLAB. These measures collectively contribute to the robustness of our findings and provide a methodologically sound foundation for our analysis of gamma band activity.

To wrap up the analysis, our findings suggest that gamma band activity is involved in a variety of cognitive functions. Further research is needed to understand the specific role of gamma band activity in these cognitive processes.

## V. LIMITATIONS

Our study aims to shed light on gamma band activity in EEG signals using a comprehensive extraction approach. Below, we outline the identified limitations and elaborate on their connection to our methodology and findings.

One limitation of our approach arises from the spatial resolution of EEG measurements, particularly the potential for volume conduction effects and the limited spatial accuracy in localizing neural sources. This limitation is inherent in EEG and can affect the precise identification of the neural generators of gamma band activity. Although our methodology employs a subset of electrodes optimized for gamma band analysis, the accurate localization of the neural sources contributing to the observed gamma oscillations may be challenging.

The presence of noise and artifacts in EEG recordings can pose challenges to the accurate extraction of gamma band activity. Despite employing robust artifact removal techniques, residual noise may persist, influencing the quality of our extracted signals. While our methodology strives to enhance the signal-to-noise ratio through preprocessing steps and digital filtering, the potential influence of artifacts remains a consideration in the interpretation of our results.

The interpretability of our findings is affected by the complex nature of neural activity which encompasses a multitude of cognitive and physiological processes. While our methodology provides insights into gamma band oscillations, the precise cognitive functions underlying these oscillations may not always be straightforward to perceive. The linkage between gamma activity and specific cognitive processes requires careful consideration and integration with other behavioural and neuroimaging measures.

We recognize the importance of aligning the limitations of our methodology with our proposed approach to provide a holistic view of our research. Despite these limitations, our methodology offers valuable insights into gamma band activity, its potential neural sources and its implications for understanding dyslexia and bilingualism. Our commitment to transparency and rigor ensures that the limitations we acknowledge contribute to a nuanced interpretation of our results, informing future research directions in the field.

## VI. CONCLUSION

The results of this study suggest that gamma band activity is significantly decreased in individuals with dyslexia. This finding is consistent with previous research that has shown that gamma band activity is important for a variety of cognitive functions, including attention, working memory and language processing. The decreased gamma band activity in individuals with dyslexia may contribute to their difficulties in these areas. After successfully extracting gamma band activity from EEG signals using bandpass filters, there are several exciting future directions for further exploration. Researchers can investigate the functional significance of gamma band activity in different cognitive processes and brain functions. By studying the relationship between gamma oscillations and specific tasks or mental states, researchers can gain deeper insights into the role of gamma bands in cognition and potentially uncover new biomarkers for cognitive disorders or neurological conditions. Advancements in source localization techniques can help elucidate the precise neural generators of gamma activity, allowing for a more detailed understanding of the underlying neural circuits involved. Integrating gamma band analysis with other neuroimaging modalities, such as functional magnetic resonance imaging (fMRI) or electrocorticography (ECoG) can provide a multimodal perspective on brain activity and enhance our understanding of the dynamics and functional connectivity associated with gamma oscillations. Lastly, ongoing technological advancements in EEG hardware and signal processing methods hold promise for improving the quality and resolution of gamma band extraction, enabling more accurate and reliable analysis. The successful extraction of gamma band activity opens up exciting avenues for further research, with the potential to deepen our understanding of brain function and contribute to the development of novel diagnostic and therapeutic approaches. This research could lead to the development of new interventions for dyslexia that target gamma band activity.

## ACKNOWLEDGEMENT

This research project was conducted without any external funding support.

## REFERENCES

- [1] M. J. Dahl, M. Mather, M. Werkle-Bergner, "Noradrenergic modulation of rhythmic neural activity shapes selective attention", *Trends in cognitive sciences*, vol. 26, pp. 38-52, 2022.
- [2] H. Bharadwaj, F. Mamashli, S. Khan, R. Singh, R. M. Joseph, A. Losh, S. Pawlyszyn, N. M. McGuiggan, S. Graham, M. S. Hamalainen, T. Kenet, "Cortical signatures of auditory object binding in children with autism spectrum disorder are anomalous in concordance with behavior and diagnosis", *PLoS Biology*, vol. 20, 2022.
- [3] P. Wendiggensen and C. Beste, "How Intermittent Brain States Modulate Neurophysiological Processes in Cognitive Flexibility," *Journal of Cognitive Neuroscience*, vol. 35, 2023.
- [4] Y. Andrade-Talavera, A. Fisahn, A. Rodriguez-Moreno, "Timing to be precise? An overview of spike timing-dependent plasticity, brain rhythmicity, and glial cells interplay within neuronal circuits", *Molecular Psychiatry*, vol. 28, no. 6, pp. 2177-2188, 2023.
- [5] F. B. Kayarian, A. Jannati, A. Rotenberg, E. Santarnecchi, "Targeting Gamma-Related Pathophysiology in Autism Spectrum Disorder Using Transcranial Electrical Stimulation: Opportunities and Challenges", *Autism research*, vol. 13, no. 7, pp. 1051-1071, 2020.
- [6] X. Xie, H. Liu, M. Shu, Q. Zhu, A. Huang, X. Kong, Y. Wang, "A multi-stage denoising framework for ambulatory ECG signal based on domain knowledge and motion artifact detection", *Future Generation Computer Systems*, vol. 116, pp. 103-116, 2021.
- [7] M. Assem, M. G. Hart, P. Coelho, R. Romero-Garcia, A. McDonald, E. Woodberry, R. C. Morris, S. J. Price, J. Suckling, T. Santarius, J. Duncan, "High gamma activity distinguishes frontal cognitive control regions from adjacent cortical networks", *Cortex*, vol. 159, pp. 286-298, 2023.
- [8] D. Gorjan, K. Gramann, K. De Pauw, U. Marusic, "Removal of movement-induced EEG artifacts: current state of the art and guidelines," *Journal of neural engineering*, vol. 19, pp. 011004, 2022.
- [9] C. Beste, A. Munchau, C. Frings, "Towards a systematization of brain oscillatory activity in actions", *Communications Biology*, vol. 6, pp. 137, 2023.
- [10] B. Peng, Y. Zhang, M. Wang, J. Chen, D. Gao, "TA-MFFNet: Multi-feature fusion network for EEG analysis and driving fatigue detection based on time domain network and attention network", *Computational Biology and Chemistry*, vol. 104, pp. 107863, 2023.
- [11] P. Podder, M. M. Hasan, M. R. Islam, M. Sayeed, "Design and Implementation of Butterworth, Chebyshev-I and Elliptic Filter for Speech Signal Analysis", *arXiv preprint arXiv*, 2020.
- [12] P. Gaur, R. B. Pachori, H. Wang, G. Prasad, "An Automatic Subject Specific Intrinsic Mode Function Selection for Enhancing Two-Class EEG-Based Motor Imagery-Brain Computer Interface," *IEEE Sensors Journal*, vol. 19, pp. 6938-6947, 2019.
- [13] E. Arrufat-Pie, M. Estevez-Baez, J.M. Estévez-Carreras, C. Machado-Curbelo, G. Leisman, C. Beltran, "Comparison between traditional fast Fourier transform and marginal spectra using the Hilbert–Huang transform method for the broadband spectral analysis of the electroencephalogram in healthy humans", *Engineering Reports*, vol. 3, pp. e12367, 2021.
- [14] V. V. Moca, H. Barzan, A. Nagy-Dabacan, R.C. Muresan, "Time-frequency super-resolution with superlets", *Nature communications*, vol. 12, pp. 337, 2021.
- [15] Y. Zhou, A. Sheremet, Y. Qin, J. P. Kennedy, N. M. DiCola, S. N. Burke, A. P. Maurer, "Methodological Considerations on the Use of Different Spectral Decomposition Algorithms to Study Hippocampal Rhythms", *Eneuro*, vol. 6, 2019.
- [16] L. P. Arts and E. L. van den Broek, "The fast continuous wavelet transformation (fCWT) for real-time, high-quality, noise-resistant time–frequency analysis", *Nature Computational Science*, vol. 2, pp. 47-58, 2022.
- [17] M. Chalakli and H. Omranpour, "Epileptic seizure classification using ConvLSTM deep classifier and rotation short-time Fourier Transform," *Journal of Ambient Intelligence and Humanized Computing*, vol. 14, pp. 3809-3825, 2023.
- [18] W. Bounoua, M. F. Aftab, C.W. P. Omlin, "Online detrended fluctuation analysis and improved empirical wavelet transform for real-time oscillations detection in industrial control loops", *Computers & Chemical Engineering*, vol. 172, pp. 108173, 2023.
- [19] J. Dan, B. Vandendriessche, W. V. Paesschen, D. Weckhuysen, A. Bertrand, "Computationally-Efficient Algorithm for Real-Time Absence Seizure Detection in Wearable Electroencephalography," *International Journal of Neural Systems*, vol. 30, pp. 2050035, 2020.
- [20] A. Yilmaz and G. Bayrak, "A new signal processing-based islanding detection method using pyramidal algorithm with undecimated wavelet transform for distributed generators of hydrogen energy," *International Journal of Hydrogen Energy*, vol. 47, pp.19821-19836, 2022.
- [21] N. Abu Farha, F. Al-Shargie, U. Tariq, H. Al-Nashash, "Improved Cognitive Vigilance Assessment after Artifact Reduction with Wavelet Independent Component Analysis", *Sensors*, vol. 22, no. 8, pp. 3051, 2022.
- [22] B. Pang, M. Nazari, G. Tang, "Recursive variational mode extraction and its application in rolling bearing fault diagnosis", *Mechanical Systems and Signal Processing*, vol. 165, pp. 108321, 2022.
- [23] A. Palumbo, V. Gramigna, B. Calabrese, N. Ielpo, "Motor-Imagery EEG-Based BCIs in Wheelchair Movement and Control: A Systematic Literature Review", *Sensors*, vol. 21, pp. 6285, 2021.
- [24] S. Nobukawa, T. Yamanishi, S. Kasakawa, H. Nishimura, M. Kikuchi and T. Takahashi, "Classification Methods Based on Complexity and Synchronization of Electroencephalography Signals in Alzheimer's Disease", *Frontiers in psychiatry*, vol. 11, pp. 255, 2020.
- [25] R. Nawaz, K. H. Cheah, H. Nisar, V. V. Yap, "Comparison of different feature extraction methods for EEG-based emotion recognition", *Biocybernetics and Biomedical Engineering*, vol. 40, pp. 910-926, 2020.
- [26] Y. Li, A. Liu, X. Fu, M. J. Mckeown, Z. J. Wang, X. Chen, "Atlas-guided parcellation: Individualized functionally-homogenous parcellation in cerebral cortex", *Computers in Biology and Medicine*, vol. 150, pp. 106078, 2022.

- [27] F. Rodriguez, S. He, H. Tan, “The potential of convolutional neural networks for identifying neural states based on electrophysiological signals: experiments on synthetic and real patient data”, *Frontiers in Human Neuroscience*, vol. 17, pp. 1134599, 2023.
- [28] T. J. Gawne, G. J. Overbeek, J. F. Killen, M. A. Reid, N. V. Kraguljac, T. S. Denney, C. A. Ellis and A. C. Lahti, “A multimodal magnetoencephalography 7 T fMRI and 7 T proton MR spectroscopy study in first episode psychosis”, *NPJ Schizophrenia*, vol. 6, pp. 23, 2020.