International Journal on Robotics, Automation and Sciences

Design and Development of Automated Solar Grass Trimmer with Charge Control Circuit

Thangavel Bhuvanewari*, Venugopal Chitra, Sarah Immanuel, Emerson Raja, Chua Wei Chern

Abstract - The focus of this paper is the design and development of an automatic solar grass trimmer prototype, emphasizing high operational efficiency with renewable energy as the primary power source. This solar-based device not only contributes to reduced air pollution but also aligns with environmental sustainability objectives. The prototype features a charge control circuit and is powered by a rechargeable 12V battery. To address low battery levels, a solar panel is employed for automatic recharging. A DC-DC buck converter is integrated to step down the higher voltage from the solar panel to match the battery requirements. Safety features, such as a current limiter and overcharge protection circuits, have been incorporated into the design. The paper provides a detailed discussion on the conceptual design of the solar grass trimmer, including the placement of sensors and motors. Additionally, the cutting motor force analysis and total weight calculation of the prototype are presented. The solar charge control circuit, along with details on the current limiter and overcharge protection circuit, is thoroughly explored. Successful development of the prototype is reported, and the battery charging circuits are analyzed using a Bench PSU and solar panel. The paper includes plots of voltage, current, and power generated by the solar panel under various weather conditions. A comparison between Bench PSU

and solar panel power is also provided. This research contributes to the advancement of automated solar-powered devices, offering sustainable solutions for environmentally friendly grass trimming.

Keywords—Solar, Grass Trimmer, Charge Control Circuit, Microcontroller, Overcharge Protection, Current Limiter.

I. INTRODUCTION

In 1830, Edwin Budding created the first lawn mower in Thrupp, Gloucestershire, England, just outside of Stroud. Budding's mower, which was awarded a British patent on August 31, 1830, was meant to cut the lawn on sports fields and large garden areas as a preferable alternative to the scythe [1]. In the year 1995, the first entirely robotic mower powered by solar was released to replace traditional lawn mowers with motorized engines that required regular maintenance like oil and grease. They also contribute to pollution, such as noise and air pollution. The engine powered by gasoline tends to freeze or stop working in cold and severe environments. These issues have been resolved.

*Corresponding author email: t.bhuvanewari@mmu.edu.my

Thangavel Bhuvanewari is with Faculty of Engineering and Technology, Multimedia University, Jalan Ayer Keroh Lama, 75450 Melaka, Malaysia (corresponding author) phone: +6062523028, fax: +606 231 6552(e-mail: t.bhuvanewari@mmu.edu.my).

Venugopal Chitra is from Department of Renewable Energy, Oregon Institute of Technology, Wilsonville, OR, USA. (e-mail:chitra.venugopal@oit.edu).

Sarah Immanuel is attached with Business and Information Systems, Torrens University, Australia (e-mail-sarah.immanuel@torrens.edu.au).

Emerson Raja is with Faculty of Engineering and Technology, Jalan Ayer Keroh Lama, Multimedia University,75450 Melaka, Malaysia (e-mail: emerson.raja@mmu.edu.my).

Chua Wei Chern is with Faculty of Engineering and Technology, Jalan Ayer Keroh Lama, Multimedia University,75450 Melaka, Malaysia(e-mail: busakthi2208@gmail.com)

The modern lawn mower uses radio frequency emissions to locate its charging station by moving along with the boundary wire. This can avoid lawn wear patterns created by the mower's ability to only return to the station through one wire. A robotic lawn mower is an automatic device that cuts grass automatically. A border wire is to be installed around the grass by the user to designate the mowing area for a normal robotic lawn mower. The robot uses the perimeter wire to determine the area to be cut and, in some situations, to identify a recharging port. Robotic mowers, in general, can mow up to 20,000 square meters of grass.

The solar grass cutters have improved to the point where they can now self-dock and, if necessary, rain sensors, almost eliminating the need for human participation. Throughout the years, lawn mower technology has gone through several advancements.

Hence, it is better to do an analysis of the influence of robots on both humans and the environment [2]. With a traditional gas-powered lawn mower, pollution is a serious problem. Another aspect that has to be eliminated is human effort. Some robotic mowers have improved the functionality within custom apps to alter settings or plan mowing time needs to be taken, it can also be manually operated by the user with a digital joystick, due to the rise of smart phones.

Design of solar grass trimmer prototype along with the battery charging circuits is the main objective of this paper. The concept design of solar grass trimmer and the placement of sensors and motors along with the cutting motor force analysis and the total weight calculation of the prototype is discussed in detail. The DC - DC buck converter circuit, Current Limiter circuit, overcharge protection circuit designs are added. The Battery Charging circuit developed are tested using a Bench PSU, Solar Panel etc. The voltage, current and power of the solar panel under different weather conditions are plotted for analysis. The literature related to this objective is discussed.

In [1] the design of a solar powered autonomous lawn mower robot that can be remotely controlled through a mobile phone is proposed. The proposed design has a variety of features like path finding, trimming of grass, obstacle avoidance by infrared motion body detection. It uses ultrasonic sensor and PIR sensors for obstacle & path finding and motion detection respectively. The design is simulated using proteus software. In [3], an autonomous solar powered, obstacle avoidance and path planning grass cutting robot is proposed by A.O. Adeodu. Obstacle avoidance was achieved using infrared sensor and the path planning for area covering was achieved by 2D laser scanner.

In [4] Vanishree et al. proposed a design of a manual grass cutter machine for low-height grass. In this paper, an analysis using ANSYS software is performed on a cutting roller and horizontal cutting

blade. The proposed design has the capacity to cut grass economically and faster.

The fabrication and working of a smart solar grass cutter is designed by Jabbar et al. [5]. Micro controller is utilized in the prototype to control the different lawn mower actions. This new prototype for the remotely controlled grass cutter was designed using Arduino UNO to be connected via Bluetooth using a smartphone.

Balakrishna et al. proposed IoT (Internet of Things) technology based Arduino UNO-based Solar powered Grasscutter design. Blynk application is used in this prototype to control the robot remotely through Bluetooth module. It can move the robot in all the four directions left, right, backward and forward. The designed prototype can move in all directions and detect the obstacle from colliding while in movement [6].

In [7] D. Satwik et al. proposed a lever operated solar lawn mower design, where it cuts grass at various heights. Grass cutting at various heights is possible by lever adjustment by gear displacement mechanism. The various components used in this design are Arduino board, solar panel, battery, a rotor blade, ultrasonic sensor, wheels & gears and a DC motor.

Dual Axis Solar Tracker (DAST) is a low-cost design for solar Trackers proposed by Thangavel Bhuvaneshwari et.al. [8]. The authors have fabricated a low-cost mechanical structure using this design and performed the stress analysis for the Auto CAD simulation. The vertical movement of the tracker is simulated using Linkage software. The dual axis solar tracker model is portable and efficient. It can be easily moved to any places for power generation where the sun light is available. An experimental study is done by Thangavel Bhuvaneshwari et.al. in [9] using the mechanical structure developed in [8]. Identification of maximum intensity of sunlight is done with the help of a microcontroller with 4 LDR sensors. LDR sensors are used to provide input to the microcontroller.

The clockwise and the counterclockwise rotation of the motor is performed by using a stepper motor with a pulley and belt. Whereas a linear actuator is used to control the up/down movements (elevation).

The microcontroller decides the action to be taken by comparing the measurement of the light intensity of the sun provided by the light sensors kept in all the four directions (north, south, east and west). The tracking will be turned off if the N(Night) switch is triggered manually. Arduino microcontroller based dual axis solar tracker has been designed and tested successfully for its operation in lower cost. Dual axis tracking has been verified along with MPPT controllers. It has been observed that tracking is more efficient than fixed panel, and much efficient with MPPT controller. These solar panel tracking systems

are playing an important role in the efficient operation of solar powered systems.

In [10] Ariff et al. carried out the survey to identify the various issues regarding the use of intelligent controllers for solar panel tracking systems and the results are very useful for further research in designing efficient solar tracking systems. A proposal is also made for the application of neuro-fuzzy controller based solar panel tracking system after observing the results of this survey.

Gardening takes a long time and requires a lot of effort. It applies chemical insecticides to remove weeds at the same time. Karthick et al. proposed an automated weeding rover for grass fields in [11]. It keeps the garden weed-free without the need of pesticides. To get rid of weeds, this robot uses a spinning trimmer powered by a DC motor. The weed trimmer on the robot is activated by the sensor. This robot can tell the difference between a growing weed and garden greenery without difficulty. Place the plant collar around seedlings to let them know they're wanted. Once the plants have grown, it is possible to remove the collar and allow the weeder to continue working in the garden. The proposed method needs huge investment because of the plant collar. A smartphone application may be used to operate the robot (Arduino Bluetooth control).

Shinde Vaibhav Tanaji et al. proposed a type of robotic lawn mower based on solar powered vision in [12]. It is a self-driving grass cutter machine that allows the user to cut their lawn with minimum effort. It detects the boundary wire and starts mowing upon the predefined pattern with the help of the camera and the MATLAB program. Some pre-set patterns are put in the robot, requiring no human effort for operation in the automated mode, and assisting in cutting different patterns on the grass quickly and efficiently. This lawn mower makes use of solar energy by using a solar panel and solar photovoltaic cells to power an electric motor [13].

In [14] Zin Mi Mi Ko et al. proposed a new type of automatic lawn mower construction is discussed. It has two systems: automatic and remote. The solar panels are used to power the device. During the cutting process, the battery can be charged.

It can be remotely controlled with the help of the RF module provided for wireless communication (Transmitter/Receiver) [15]. The ON/OFF operation is achieved using a toggle switch. The forward, backward, left, and right movement of the grass cutter is performed by a joystick. An LCD Display is used to show the current direction of the grass cutter and the various instructions to be given to the grass cutter remotely during the operation.

The proposed methodology and concept design are discussed in section II. The solar charge control circuit, current limiter and overcharge protection circuits are explained in detail in this section. The fully

constructed solar grass trimmer circuit and the results are analyzed in Section III. The paper ended with a conclusion and recommendations.

II. PROPOSED METHODOLOGY

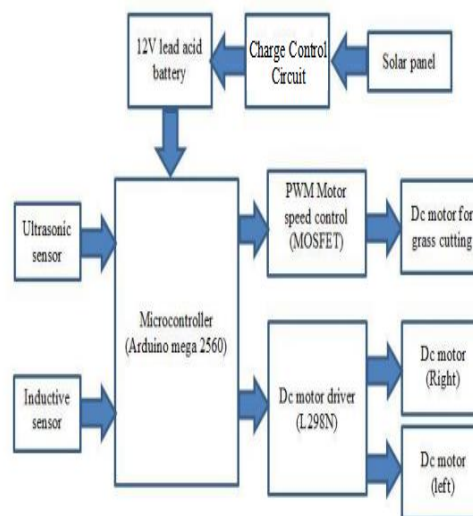

FIGURE 1: Block diagram of automated solar grass trimmer.

The block diagram of an automated solar grass trimmer is shown in Figure 1. The circuit and the Arduino mega 2560 micro-controller require to be powered up by a rechargeable 12V lead acid battery. When the battery is low, the solar panel is activated to charge the 12V battery, since the voltage from the solar panel is higher than the battery, a DC-DC buck converter is used to step down the voltage. Another necessary charging protection circuit is included in the charging stage. Two types of sensors, the inductive sensor used for boundary detection and ultrasonic is used for obstacles detection. The PWM motor speed control is a MOSFET used for grass trimming motor, so that the motor speed can be manipulated and a highspeed DC motor is required. To drive the machine, the L298N motor driver is used to control the two low rpm DC motor (left and right), low rpm provides higher torque.

A. Concept Design

The concept design of the automatic solar grass trimmer is shown in Figure 2. The wooden pieces served as the base for the components, 2.54cm x 2.54cm aluminium hollow bar as the frame and caster wheel as the front wheel. The size of the machine is 29.5cm (width) x 34cm (length). The base of the machine is made of wooden pieces. Inside the aluminium hollow bar, the where the electronic components like microcontroller, designed circuits and battery are placed. Three ultrasonic sensors are located at the left, front and right of the machine.

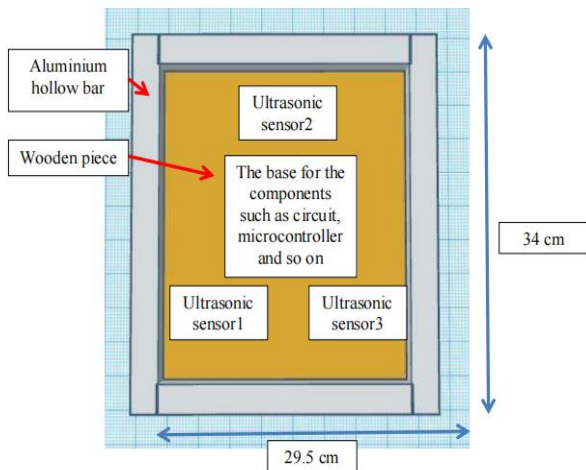

FIGURE 2. Top view of automatic solar grass trimmer.

The side view of the machine is shown in Figure 3(A). At the top of the machine is where the solar panel is located to receive the sunlight for charging the battery. The bottom part of the machine is the castor wheel, dc motor, boundary sensor and the grass cutting blade at the middle of the machine. Figure 3(B) is the front view showing the castor wheel and the boundary sensor.

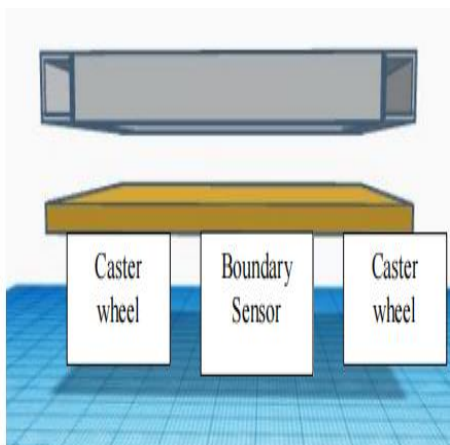

FIGURE 3(A). Side view of the automatic solar grass trimmer.

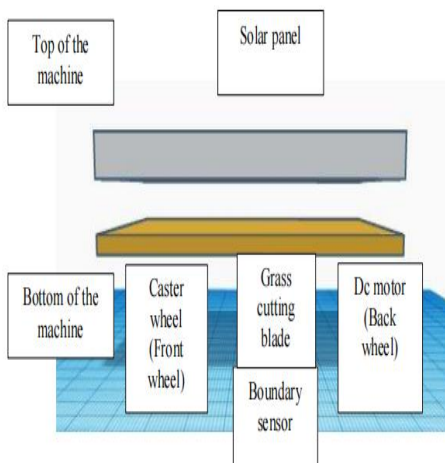

FIGURE 3(B). Front view of the automatic solar grass trimmer.

The partially completed prototype figures are shown below: the bottom view [Figure 4(A)], top view [Figure 4(B)], left side [Figure 4(C)] and right side [Figure 4(D)] of the prototype respectively. The C1 and C2 are castor wheels, these wheels move freely in 2 degrees of freedom. B1, B2 and B3 is the boundary sensor (inductor) to detect the boundary, B1 and B3 is to prevent the side of the machine cross the boundary wire and B2 to detect the end point of the first line of the cutting area. U1, U2 and U3 are ultrasonic sensors to detect obstacles, and anyone approaches the machine. The purpose of U1 and U3 are to detect whether anyone or anything is trying to approach the machine.

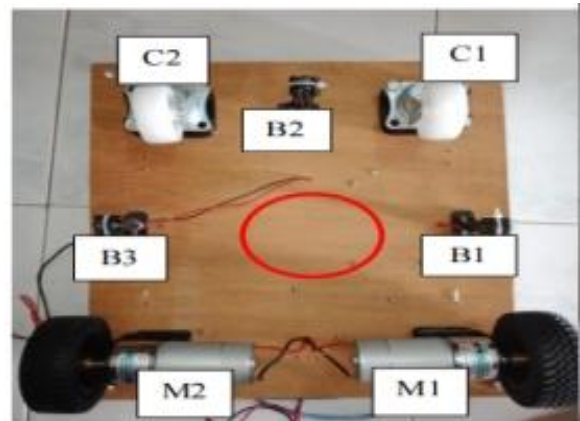

FIGURE 4(A) Bottom view.

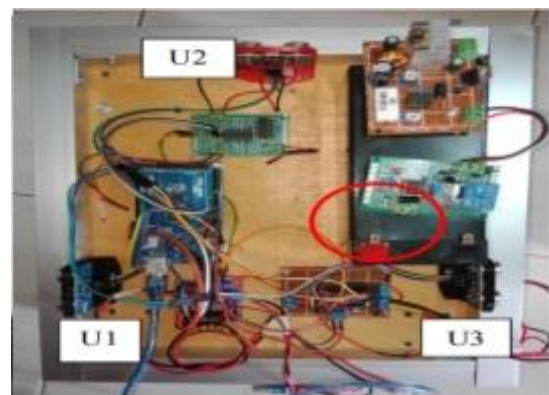

FIGURE 4(B). Top view.



FIGURE 4(C). Side view.



FIGURE 4(D). Side view.

B. Solar Charge Control Circuit

In this design, the solar charge control circuit for charging the 12V lead acid battery with the solar panel basically consists of three circuits combined as shown in Figure 5. The first section is a buck converter used to step down the dc voltage level from the solar panel to a lower voltage that can be applied to the designed circuit. The second section is the current limiter circuit; the circuit is modified based on the LM2576's capability. It can be used to limit the current flowing through the circuit by adjusting the potentiometer at the inverting input B of the LM358 operational amplifier IC. The third section is the overcharge protection circuit use to protect the 12V lead acid battery from overcharge or over-discharge. Since every battery has its lowest discharge voltage and highest charging voltage, it is necessary to protect the battery.

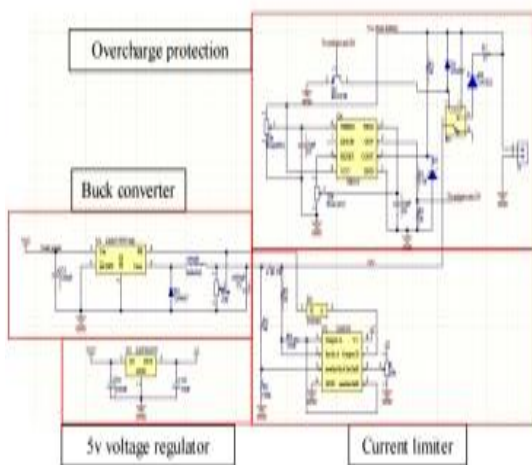

FIGURE 5. Solar charge control circuit.

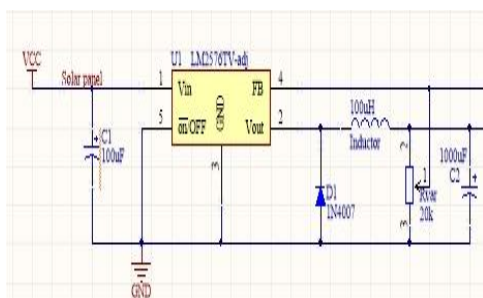

FIGURE 6(A). Schematic for dc - dc buck converter.

Since the automatic solar grass trimmer consists of a 18V monocrystalline solar panel for charging the battery and the battery in this design is 12V, the buck converter (step down converter) is to step down the dc voltage level from the input to lower voltage at the output for enabling the battery get charged at correct voltage level as shown in Figure 6(A) [16]. The LM2576 IC has 5 pins, Vin, Vout, GND, FB and ON/OFF. The FB pin of the IC will be connected to the output for feedback control, it uses to maintain the output voltage at same voltage level when facing different kind of situation that was going to force the change of output voltage. The ON/OFF pin is to turn on or off of the IC.

C. Current Limiter

Figure 6(B) shows the current limiting circuit for the charging circuit, or it can be called as short circuit protection. Since the LM2576 IC has a feedback pin which can be control output, taking this advantage to modify the circuit. In this design, LM358 operational amplifier IC to construct this circuit. On the output side of the buck converter consists of a 0.1Ω sense resistor, as a sensor to detect the overcurrent flow.

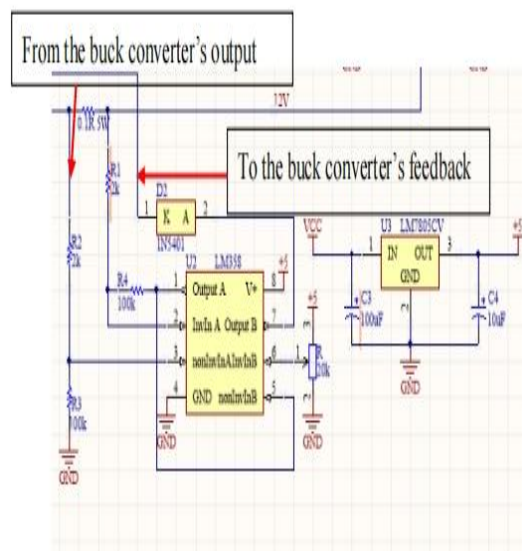

FIGURE 6(B). Schematic of current limiter circuit.

The small voltage drop across the resistor is calculated by using the formula in (1).

$$V = IR \tag{1}$$

For example, the current flowing through the resistor is 1A, then $V = 1A \times 0.1\Omega = 0.1V$. Since the voltage detected is very small, the operational amplifier is used to amplify the 0.1V. The LM358 operational amplifier consists of dual amplifiers inside the IC, the first amplifier is a differential amplifier to amplify the 0.1V. By using the formula in (2).

$$V_{out} = \frac{R4}{R2} * V_{in} \tag{2}$$

V_{out} can be calculated as $V_{out} = (100k\Omega/2k\Omega) \times 0.1V = 5V$ which means the gain of this amplifier is 50. Then the 5V is feed to the noninverting of the second amplifier. The second amplifier without the feedback will act as a comparator to compare the adjusted voltage (with potentiometer) at the inverting input with the voltage at the non-inverting. When the voltage at noninverting is higher than inverting side, the output is pull to high and feedback to the LM2576's FB pin to prevent over current flow happens at the output. This is how the LM2576 Circuit is modified by adding another current limiter circuit to it. The completed circuit of LM2576 with current limiter is shown in Figure 6(C).

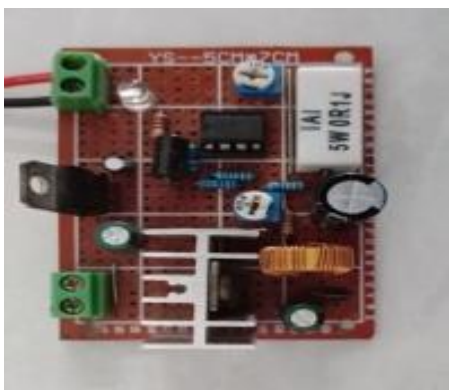

FIGURE 6(C). The combined circuit of buck converter and current limiter.

D. Overcharge Protection

In this design, a battery is used to power up everything inside the automatic solar grass trimmer. To protect the 12V lead acid battery from overcharge or over-discharge, a circuit shown in Figure 6(D) is constructed to protect the battery. Every battery has its own lowest discharge voltage and highest charging voltage, the circuit design needs to be adjusted to meet the lowest and highest voltage needed for the user. The NE555 timer is being used in this circuit to do the comparison of the battery voltage whether it is achieved lowest or highest voltage set by the user. A relay is used to cut-off the battery from charging when it is fully charged.

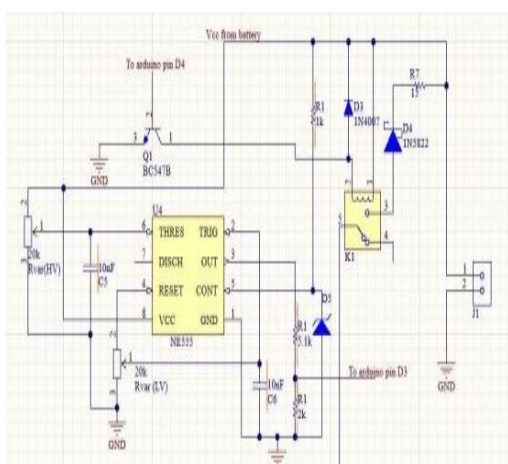

FIGURE 6(D). Schematic of overcharge protection circuit.

The 555 timer IC shown in Figure 6(E) generates accurate and consistent time or oscillation delays in general [17].

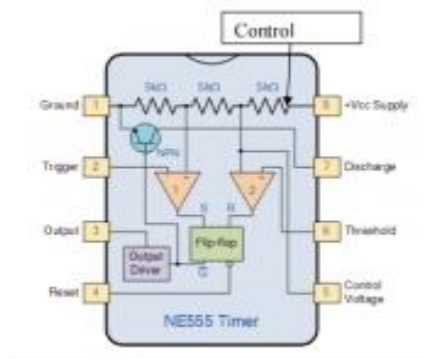

FIGURE 6(E). NE555 timer ic.

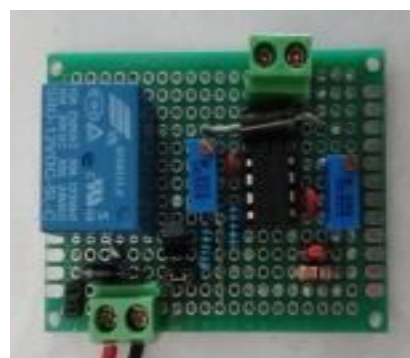

FIGURE 6(F). The completed overcharge protection circuit.

The operating voltage of IC is between 4.5V to 15V DC supply. A flip-flop, a voltage divider, and a comparator are the functional components of the 555 timer IC. The main function of this IC is to generate a continuous precise timing pulse. The delay of this IC during the monostable mode is adjusted by external components such as a variable resistor and capacitor. The duty cycle and frequency are regulated by two external resistors and one capacitor in the astable mode.

In 555 timers, in between V_{cc} and ground, there are three internally connected 5kΩ resistor which it uses to generate the two comparators reference voltages. In the constructed circuit, there is a 6.2V Zener diode with reverse voltage of 6.2V connected to the control voltage pin of the IC. In the 555Timer IC that pin is connected to the inverting of the second comparator and the voltage divider. The Zener diode will force the inverting input of second comparator and the remaining two 5kΩ resistor to remain at 6.2V, and the reference voltage generated from the voltage divider at non-inverting of the first comparator will be 3.1V. This voltage level will remain unchanged unless the supply voltage is below 6.2V. There are two 20kΩ potentiometer connected to trigger and threshold pin respectively. The trigger pin is to set the lowest cut-off voltage and the threshold is to set the highest cut-off voltage.

First, the IC is supplied with lowest cut-off voltage and tune the potentiometer for trigger until the output is switch to ON (voltage drops below $1/2V_{zener}$ diode), then the IC is supplied with highest cut-off voltage and tune the potentiometer for threshold until the output is switch to OFF (voltage applied to it exceeds V_{zener} diode), that completes the setting. The supply voltage through the potentiometer and to the trigger and threshold pin will change according to the change of battery voltage level, means that the inverting input (-) of first comparator and non-inverting (+) input of second comparator will be altered depending on the battery, but the non-inverting (+) input of first comparator and inverting input (-) of the second comparator voltage level will remain at 3.1V and 6.2V due to the Zener diode connected at the control voltage pin. These will cause the output turn ON or OFF when the battery voltage is changing. By using this opportunity to detect whether the battery is fully charged or not. The complete circuit is shown in Figure 6(F).

III. RESULTS AND DISCUSSIONS

A. Automated Solar Grass Trimmer

Figure 7(A) and Figure 7(B) shows the automatic solar grass trimmer prototype, the machine has 4 wheels, two dc motor wheels to drive the machine and two castor wheels located at the bottom part of the machine. The bottom of the machine also consists of boundary sensor and the grass cutting motor blade. In Figure 7(B) side view shows the base of the machine; the main components like microcontroller, motor driver, battery, charging circuit, ultrasonic sensor and so on are placed. Figure 7(A) shows the top of the machine, and this is the position for the solar panel to obtain the sunlight.



FIGURE 7(A). The top and front view of the completed machine.

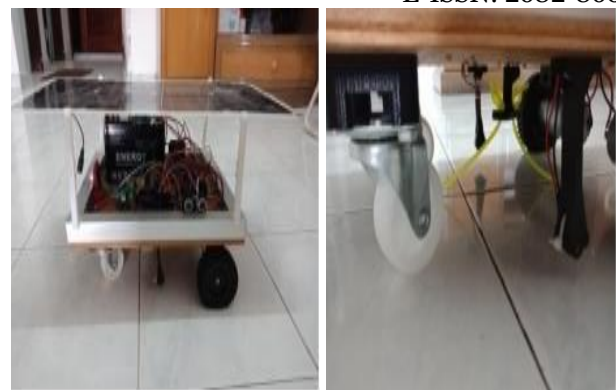

FIGURE 7(B). Tthe side and bottom view of the completed machine.

B. Drive Motor

Because of its wide availability and low cost, brushed DC geared motor is used for the machine. The total mass of the overall machine design, the total forces that will be applied to it during motion, needs to be calculated to determine the capacity of the drive motor. By summing the individual mass of the components, the overall mass can be calculated.

TABLE 1. The total weight of the machine.

Item	Weight (Kg)
Whole structure of the machine	1.50
Drive motor holder	0.10
Cutting motor	0.25
Drive motors	0.35
Solar panel	0.82
12V lead acid battery	1.80
Overall of the rest of the electronic components	0.50
Overall of the rest of the accessories	0.10
Total mass	5.4286

Based on the data sheet of the geared dc motor has a torque of 15kg.cm, this means that a "force" of 15 kg acting at a radius of 1cm. The radius of the wheel attached to the driver motor is 4cm. The torque required for the driver to move the machine with the 4cm radius wheel is calculated using (3), (4), (5) respectively.

$$Torque = mass * radius \tag{3}$$

$$Mass = \frac{Torque}{radius} \tag{4}$$

$$Mass = 15Kg * \frac{cm}{4cm} = 3.75kg \tag{5}$$

For two drive motors, the total force is $2 \times 3.75 = 7.5kg$ at a radius of 4cm. So, the total mass of the machine < the calculated mass ($5.42kg < 7.5kg$),

therefore, should not be a problem for the driver motor to move the machine.

high. The efficiency is determined in power by using (10) below:

C. Cutting Motor Analysis

$$Power P = Voltage * Current \quad (10)$$

The cutting head is a simple cutting head with two nylon grass trimmer line and placed under the machine at the fixed height of roughly 4cm. The machine is only suitable for short grass cutting between 4cm to 11cm in height. Since the ultrasonic sensor's position is quite low, it might detect the grass above 11cm as an obstacle. Therefore, the ultrasonic sensor should be placed at even higher position to reduce the error occurring. The trimmer head was estimated to be 4cm high from the ground, as shown in Figure 8.

E. Analysis for the Battery Charging Using Bench PSU

The analysis of the battery is conducted as shown in Figure 9. The 12V lead acid battery is charged by using the bench power supply. Since the bench power supply was able to provide constant output, the battery voltage constantly increased until it reached the maximum voltage and stays saturated as shown in Figure 9(A). The current will decrease slowly when the battery voltage increases. When the battery voltage stays saturated, the current draw from the bench power supply decreases rapidly until it reaches almost zero as shown in Figure 9(B). The Battery charging power using Bench PSU is shown in Figure 9(C).



FIGURE 8. The trimmer head of the machine.

The cutting motor speed is around 3000rpm for smooth and effective cutting. By using (6), (7), (8), (9) below to calculate the force of the cutting motor:

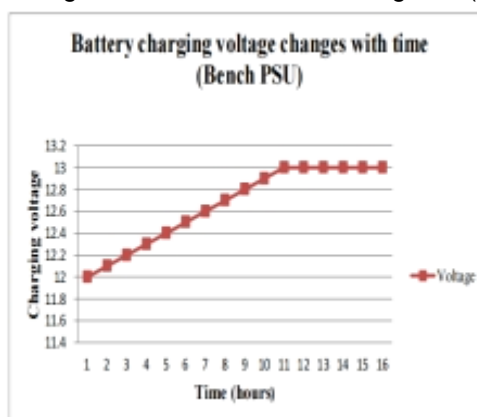

FIGURE 9(A). Charging voltage vs time (Bench PSU).

Motor Speed, $N = 3000rpm$

$$Power P = V * I = 12 * 0.417 = 5W \quad (6)$$

$$Angular\ Speed(\omega) = \frac{2\pi N}{60} = \frac{2 * 3.14 * 3000}{60} \quad (7)$$

$$Torque = \frac{P}{\omega} = \frac{5}{314.16} = 0.016Nm \quad (8)$$

$$Force, F = \frac{T}{R} = \frac{0.016}{0.018} = 0.9N \quad (9)$$

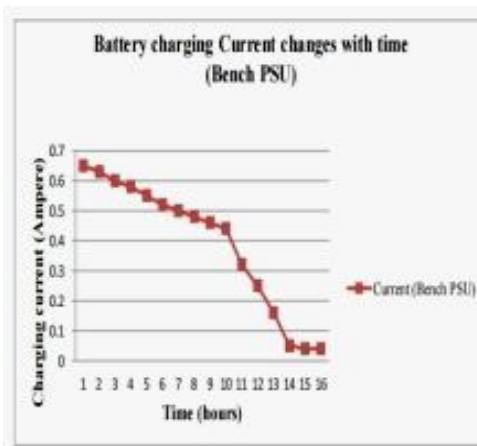

FIGURE 9(B). Charging current vs time (Bench PSU).

D. Analysis of Battery Charging Using Different Methods

The purpose of the experiment was to compare the battery charging voltage and current changes with time and the efficiency of solar panels. The charging voltage and current changes over time are tested with a bench power supply and the solar panel to study the difference between these methods. The efficiency of the solar panel has been analysed to find out what kind of weather or what time in a day that efficiency is

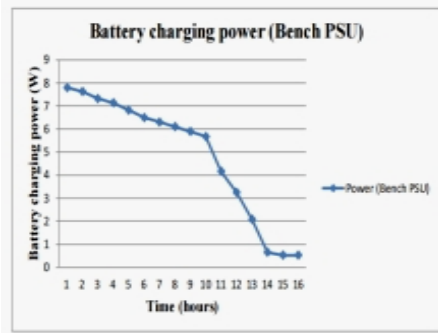

FIGURE 9(C). Charging power vs time (Bench PSU).

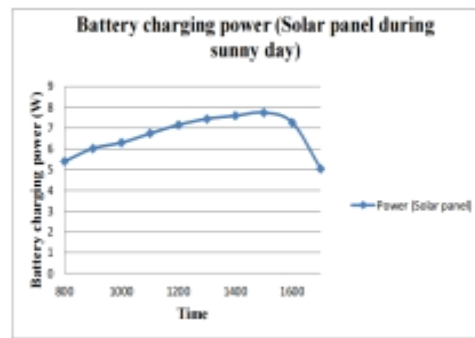

FIGURE 10(C). Charging power vs time (solar panel).

F. Analysis of the Battery Charging Using Solar Panel

The analysis of the battery charging using the Figure 10(A) and 10(B). It is observed that the solar panel's efficiency varies with time and weather. In order to get the optimal output data from the solar panel, the test is conducted during sunny day. From Figure 10(a), it is observed that the battery charging voltage is not increasing constantly due to the different periods of time, the amount of sunlight received by the solar panel, it could also be affected by phenomenon such as the sunlight suddenly blocked by the cloud. The charging current also varies due to this phenomenon. Therefore, the result might not be consistent for each time the experiment is conducted, as shown in Figure 10(B). The battery charging power with respect to time is shown in Figure 10(C). The battery charging power using Bench PSU and solar panel is also compared in Figure 10(D).

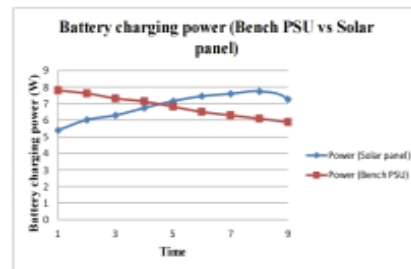

FIGURE 10(D). Bench PSU vs solar panel charging power.

Figure 11 shows the 2d column chart of open circuit voltage, short circuit current and power of the solar panel under different weather conditions. The solar panel during a sunny day has higher efficiency than the other. The output power from the solar panel during the partial sunny day is still acceptable under certain conditions. But the cloudy day is totally not efficient enough to charge the battery, not even power up a few LEDs.

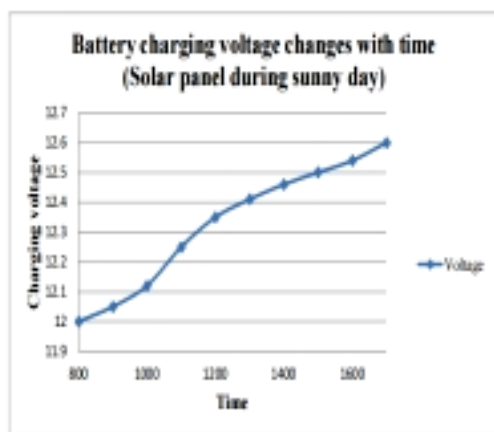

FIGURE 10(A). charging voltage vs time (solar panel).

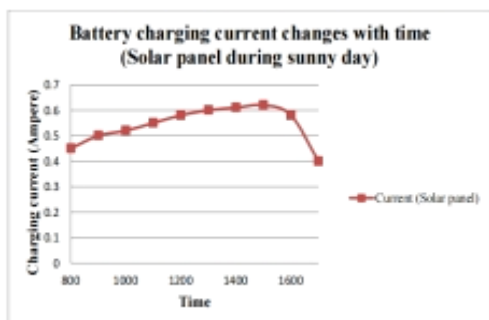

FIGURE 10(B). Charging current vs time (solar panel).

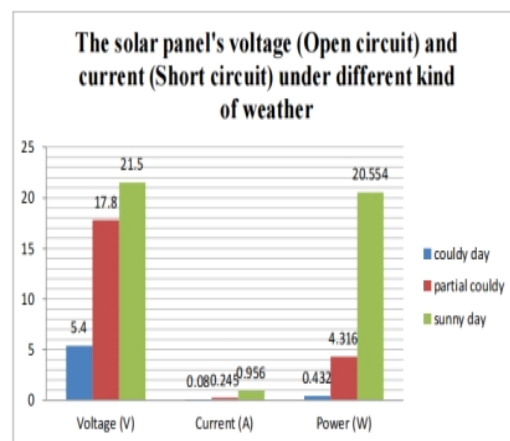

FIGURE 11. Voltage, current and power of the solar panel under different weather conditions.

Table 2 shows the open circuit voltage and short circuit current measured from the solar panel during different time periods in one day (sunny day). The solar panel seems to be more efficient during the afternoon period; this is because the sunlight during this period is the brightest, therefore the solar panel could receive full sunlight and efficiency is high. But for nighttime, the voltage and current are almost zero,

TABLE 2. The data collected from the solar panel for each period of time.

Time	Time of Day	Voltage OC (V)	Current SC (A)
8am - 11.59am	Morning	7.7 -18.4	0.1 - 0.34
12pm - 4.59pm	Afternoon	21.5 - 16.3	0.956 - 0.224
5pm - 6.59pm	Evening	15.2 - 3.6	0.12 - 0.02
7pm - 9.59pm	Night	0.2 - 0.04	0

IV. CONCLUSION

The automatic solar grass trimmer has been successfully constructed, and the results meet the specified requirements, particularly with regard to the functionality of the charge control circuits. In idle mode, the designed system effectively charges the batteries, enhancing the overall efficiency of the solar-powered grass trimmer. While the trimmer performs well for shorter grasses, its suitability for long grasses is limited due to the current configuration. To address this limitation, it is recommended that the grass cutting DC motor be replaced with a more robust motor. The current motor, being relatively small, may face challenges in handling tough grass, potentially leading to overload or excessive current flow. Upgrading to a stronger motor would enhance the trimmer's capability to handle more demanding grass-cutting tasks. Additionally, the position of the ultrasonic sensor is noted as being quite low, potentially causing it to detect grass above 11cm as an obstacle. To mitigate this error, it is advised to elevate the placement of the ultrasonic sensor to reduce false obstacle detection. This adjustment would contribute to improved accuracy in obstacle detection during grass trimming operations.

ACKNOWLEDGMENT

There is no financial support from any agencies funding this research work.

REFERENCES

[1] B. Ibrahim, V. S. Brahmaiah, & P. Sharma, "Design of smart autonomous remote monitored solar powered lawnmower robot," *Materials Today Proceedings*, 2020, vol. 28, no.4, pp.2338-2344.

[2] F. P. Madrin, H. Widyaputera, E. Supriyanto, Z. A. Malek, M. A. Abu Taib, & M. F. Mohd Yasir, "Effects of various earth grid configurations on ground potential rise caused by lightning strike," *International Journal on Robotics, Automation and Sciences (IJORAS)*, vol. 1, pp.14–20,2019.

[3] A. O. Adeodu, I. A. Daniyan, T. S. Ebimoghan, & S. O. Akinola, "Development of an embedded obstacle avoidance and path planning autonomous solar grass cutting robot for semi-structured outdoor environment," *In 2018 IEEE 7th International*

Conference on Adaptive Science & Technology (ICAST), 2108, pp. 1-11.

[4] T. S. Vanishree, C. K. Chavan, G. B. Darshan, M. S. Darshan, & M. J. Lokesh, "Design and analysis of manual grass cutter," *International Journal of Research in Engineering and Science (IJRES)*, vol. 9, no. 7, pp.43-47, 2021.

[5] M. W. Jabbar, M. Noman, A. Muneer, A. Abbas, & A. Mazhar, "Solar powered grass cutter for domestic utilization," *Engineering Proceedings*,2021, vol. 12, no.1, pp.105.

[6] K. Balakrishna, & N. Rajesh, "Design of remote monitored solar powered grasscutter robot with obstacle avoidance using IoT," *Global Transitions Proceedings*,2022, vol. 3, no. 1, pp.109-113.

[7] D. Satwik, & Ramalingeswara, "Design and fabrication of lever operated solar lawn mower and contact stress analysis of spur gears," *International Journal of Science, Engineering and Technology Research*, vol. 4, no. 8, 2015.

[8] B. Thangavel, S. C. Chee, C. Venugopal, P. Velraj Kumar, & K. Zi Yuan, "Design and fabrication of low-cost dual axis solar tracker mechanical structure," *Turkish Online Journal of Qualitative Inquiry (TOJQI)*, vol. 12, no.6, pp.1627-1638,2021.

[9] B. Thangavel, S. C. Chee, C. Venugopal, P. Velraj Kumar, & K. Zi Yuan, "Design and development of a microcontroller based automatic dual axis solar radiation tracker," *Turkish Journal of Computer and Mathematics Education*, vol.12, no. 12, pp.3149-3156,2021.

[10] E. M. H. Arif, J. Hossen, G. R. Murthy, T. Bhuvaneshwari, P. Velraj Kumar & C. Venkateshaiah, "A survey on neuro-fuzzy controllers for solar panel tracking systems," *Far East Journal of Electronics and Communications*, vol. 18, no. 7, pp.981-1003,2018.

[11] M. Karthik, P. Shanmathi, R. Shankar, & P. Sivadarshini, "Solar fed automatic weeding rover for grassland fields," *International Journal of Engineering Trends and Applications (IJETA)*, vol. 6, no. 2, pp.1-4,2019.

[12] V. T. Shinde, C. S. Chandrakant, P. S. Shashikant, G. O. Raju, & G. S. Bhalchandra, "Automated mower Robo," *International Research Journal of Engineering and Technology (IRJET)*, vol. 5, no.1, pp.343-346, 2018.

[13] F. Warsito, H. Widyaputera, E. Supriyanto, J. Puspanathan, M. A. Abu Taib, & M. F. Mohd Yasir, "Simulation of 500 MHz electromagnetic interference effect on electrical equipment with various RF grids and enclosures," *International Journal on Robotics, Automation and Sciences (IJORAS)*, vol.1, pp.21–27,2019.

[14] Z. M. M. Ko, & Z. M. Tun, "Construction of automatic solar lawn mower," *International Journal of Trend in Scientific Research and Development (IJTSRD)*, vol.3, no.5, pp.816-819,2019.

[15] Y. H. Wong, G. C. Lee, & H. K. Sim, "RFID and facemask detector attendance monitoring system," *International Journal on Robotics, Automation and Sciences (IJORAS)*, vol. 5, issue.2, pp.14–24, 2023.

[16] Buck converter basics: Working, design & application. How2Electronics.Available: <https://how2electronics.com/buck-converter-basics-working-design-application/> (Accessed: August1, 2021)

[17] 555 Timer: Working & specifications, Electronics For You. Available:[https://www.electronicsforu.com/technology-trends/learn-electronics/555-timer-working-specifications,](https://www.electronicsforu.com/technology-trends/learn-electronics/555-timer-working-specifications/)(Accessed: August1, 2021)